

Sensigas®

Gas detectors for car parks

IP55 Protection Degree

UR.20SP



11...28Vdc power supply.

Pellistor sensing element for flammable gases, and Electrochemical Cell for toxic gases.

Up to three alarm threshold.

Automatic counting life time of sensors.

Use The UR.20SP sensors, being specifically designed for car parks, are used primarily to detect the presence of Gasoline vapors and carbon monoxide (CO), but also methane gas, LPG and, on demand, nitrogen monoxide (NO) and nitrogen dioxide (NO₂).

UR.20.E sensors can be used in stand-alone mode with 4...20mA output or, in option, with an optional voltage-free contact relay card, or variable resistance output for the following operational conditions:
Pre-alarm, 1st alarm threshold, 2nd alarm threshold, Sensor Failure.

Operation In case of gas leakage the sensor compares the measured concentration value with the pre-set alarm thresholds switching on the relevant relays.
Information of the measured concentration value is always on 4...20mA output.

Ordering Simply indicate product code: please, refer to "available models".

Available models

Detectable Gas	Pellistor Standard	2 Terminal Electrochemical Cell	3 Terminal Electrochemical Cell
Methane	URG20SP	---	---
LPG	URP20SP	---	---
Carbon monoxide (CO)	---	URO20SP	---
Gasoline vapours	URB20SP	---	---
Nitrogen monoxide (NO)	---	---	URN120SP
Nitrogen dioxide (NO ₂)	---	---	URN220SP

Model on request

For other Gases, on request, please contact Customer Service

Technical characteristics

Sensing Element	Standard Catalytic, Pellistor	Electrochemical Cell
Detectable Gas (see available models)	Explosive Gas	Toxic Gas
Power supply	11÷28Vdc	11÷28Vdc
Max power consumption	3.2W	1.5W
Measurement range	0...100% LEL	0...500 ppm (CO)
Precision(Standard Catalytic Pellistor or Electrochemical Cell)	± 5% full scale range, ± 10% readout	
Repeatability	± 5% full scale range, ± 10% readout	
Measurement resolution	1% LIE	5 ppm (CO)
Microprocessor resolution	1024 points (10 bit)	1024 points (10 bit)
Digital filtering technique	Kalman Filter	Kalman Filter
Watch dog	Internal	Internal
Warm-up time	< 2m	< 2m
Stabilization time	< 2m	< 2m
Response time	< 20s (T50), < 60s (T90)	
Average Sensor life (in air)	255 weeks (from installation)	255 weeks (from production)
Output signal type:		
Proportional output (default)	- 4mA = 0% LEL; 0 ppm - 20mA = 100% LEL; 500 ppm	
Step output (thresholds applications)	- 0mA = no alarm - 10mA = 1 st threshold alarm - 20mA = 2 nd thresholds alarm	
Output reference selection	By jumpers to power supply negative or positive reference	
4...20mA output load resistor	- Up to 200Ω @ 12Vdc power supply - 200Ω ÷ 700Ω @ 24Vdc power supply	
Operation Temperature	-20 ÷ 50 °C	
Storage Temperature	-20 ÷ 70 °C	
Relative Humidity (without condensing)		
- Operation	15 ÷ 90 %RH	
- Storage	45 ÷ 75 %RH	
Operation pressure	80 ÷ 110 KPa	
Air speed	≤ 6 m/s	
Optical signal	Red LED visible during installation	
Weight & dimension	See dedicated paragraph	
Options & Accessories		
4 relay SPDT card UZR20.4	(Default values:)	
NO or NC available contact, jumpers selectable.	Relay A: Pre-alarm	10% LEL, 50 ppm
The card is also equipped with 4 led and 4 detachable terminal boards (one for each relay).	Relay B: 1 st threshold alarm	20% LEL, 100 ppm
	Relay C: 2 nd threshold alarm	40% LEL, 200 ppm
	Relay D: Sensor Failure	
	The alarm thresholds are also selectable by dipswitch or by service & maintenance terminal. See installation and start-up chapter.	
Relay maximum load:	50mA @ 24Vac/dc, 100mA @ 12Vac/dc	
Relay operation mode:	- Direct: Relay ON by event - Reverse: Relay ON without event	
Gas calibration Kit TUL40..	See installation and start-up chapter and instruction provided with Terminal Unit	
TUS40-20 Service & maintenance terminal + communication card	See installation and start-up chapter and dedicated instruction manual	
CE Conformity		
Directive / Standards EMC	Electromagnetic Compatibility Directive 2014/30/EU / EN50270 / EN 61326-1	
Directive / Standards LVD	Not applicable	

Sensors lifetime

Sensor average lifetime (see technical characteristics) is referred to a typical usage in a pollution-free environment. Presence of a high concentration of pollutants can shorten the lifetime of the sensing element.

Once the detection system starts up, it has to be supplied with energy during all the lifetime of its sensors.

Seasonal use of the detection system is not recommended.

Installation

For Sensors installation, follow the rules as in the diagram:

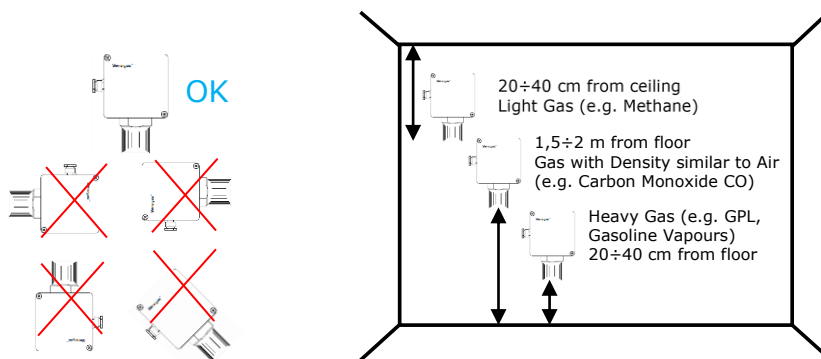

The following rules to install the detectors are strictly recommended:

1. where accidental gas leakages are possible
2. at least 1.5m far from any source of heat or point of heavy ventilation
3. not in spaces where ventilation is poor and gas-pocket can form
4. far from whatever can hinder the gas to flow naturally
5. far from appliances that throughout their normal working can have functional gas leakage
6. in spaces where temperature is between -20°C and 50°C and relative humidity lower than 90% (no dew)
7. assemble and dismantle detector only when there is no voltage.

The quantities of detectors to be installed in a room are proportional to the height and the surface of the room itself.

This parameter depends on a great range of variables, which is why **the following graph is not a rule, but a simple help for installation for light gas detectors**

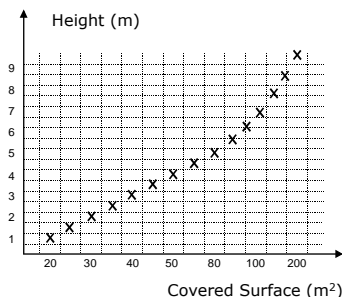

Media Coverage in m ²	Areas with normal geometry		Areas with particular geometry (beams, ceilings, wells, barriers to gas diffusion)	
	Light Gas	Heavy Gas	Light Gas	Heavy Gas
Standard Pellistor	80...100	50...80	50...80	30...50
Electrochemical Cell	100...300		60...150	

Environmental compatibility and disposal



This product has been designed and constructed using materials and processes that take into account the environmental issue. Refer to the following notes for disposal of the product at the end of its working life, or when it is replaced:

- for disposal purposes, this product is classified as an electric and electronic device: do not dispose of it with normal household waste, in particular as regards the printed circuit
- comply with all local laws in force
- as far as possible reuse basic materials to keep environmental impact to a minimum
- use local depots and waste recycling companies, or contact the supplier or manufacturer to return used products or to ask for information on environmental compatibility and waste disposal
- the product packaging can be reused. Keep it for future use or to return the product to the supplier.

Electrical Installation

WARNING: before handling the cables and configuring the system, be sure there is no voltage and the area is safe.

Install the sensor in compliance with local Standards.
To enter cables, uses the cable gland provided on the housing.

Ground the sensor by the appropriate grounding system on the housing.

Terminal board and electrical connections

Grounding system

Terminal Board TB1

12...24Vdc	+
	-
4...20mA	-
	+

JP2 triple of jumpers

Dip-Switch S1

CN4 Connector for Service Maintenance Terminal

Relay Card

Sensor Card

Relay Card guide

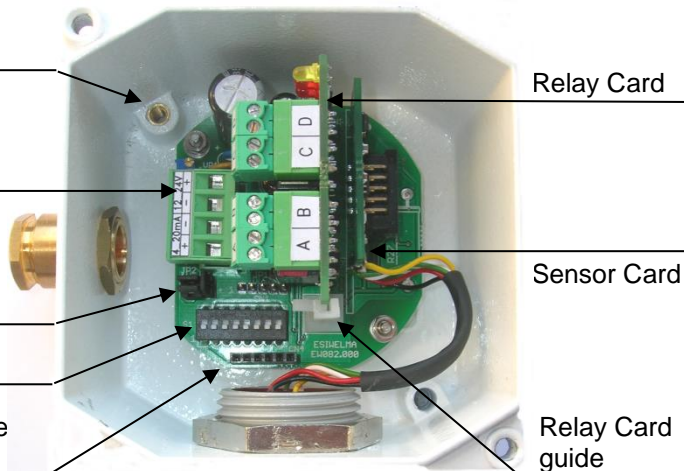

Cables:

Depending on the connecting distance, use at least a 3-conductor cable, min. cables section 0,75mm² up to 100m, 1mm² up to 200m, 1,5mm² up to 500m.
In case of electromagnetic noise, use a shielded cable.
If a relay card is used, a multiple cable suitable for the number of connections should be provided.

Configuration:

Default settings of the sensor are shown in "Technical Data" chapter.
In order to change default settings, switch off the power supply, input new settings by using JP2 triple of jumpers, or S1 dipswitch shown in the figure and switch on again the power supply; in particular:

4...20mA Output reference selection:

Output reference selection should be made by JP2 triple of jumpers; to change this setting, operator has to move **JP2** jumpers as shown in the figure:

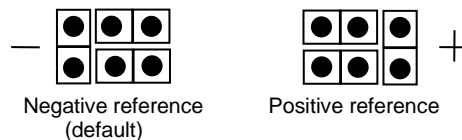

WARNING: if default setting change, the output signal polarity on **TB1** terminal board, will be inverted.

4...20mA Output signal type configuration:

To set the 4...20mA output signal type, operator has to use the 5th selector of the dip-switch in **S1** position, particularly:



Proportional Output (4...20mA)

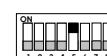

Step Output (0-10-20mA)

Alarm Thresholds settings:

To set the alarm thresholds of the optional relay card or variable resistance output, the operator has to use the first 4 selectors of **S1** dipswitch. Particularly, the thresholds, shown in full scale range percentage, will be:

(*) When the first 4 selectors of the dip-switch are in OFF position, the alarm thresholds could be set by **TUS40** Service & Maintenance Terminal. As soon this selection is set, the detector assumes the default settings as alarm thresholds. In order to set the alarm thresholds by **TUS40** Service & Maintenance Terminal, see dedicated instruction booklet.



CUSTOM (*)



3, 5, 10%



5, 10, 15%



5, 10, 20%



10, 15, 25%



10, 15, 30%

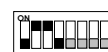

10, 20, 40% (DEFAULT)

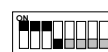

10, 25, 35%



15, 25, 40%



15, 30, 45%



25, 35, 50%



20, 40, 60%

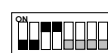

20, 40, 80%



-----Future implementation-----

Relay Card Installation

By a connector called **CN3**, placed on the main card, it is possible to add a card with 4 SPDT relays and relatives led, associated to the following functional conditions: pre-alarm, 1st threshold alarm, 2nd threshold alarm and sensor failure.
How to install the card:

Phase 1:

Insert the Relay Card Guide on the main card.
Pay attention that the elastic flag faced the main terminal board TB1.

CN3 Connector

Relay Card Guide

Elastic Flag

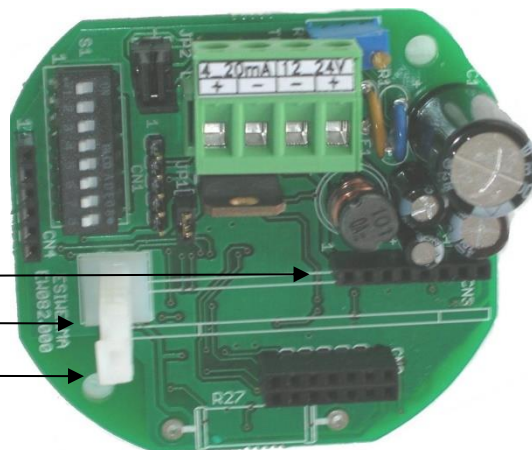

Phase 2:

Insert the Relay Card and pay attention to pull the elastic flag towards main terminal board TB1.

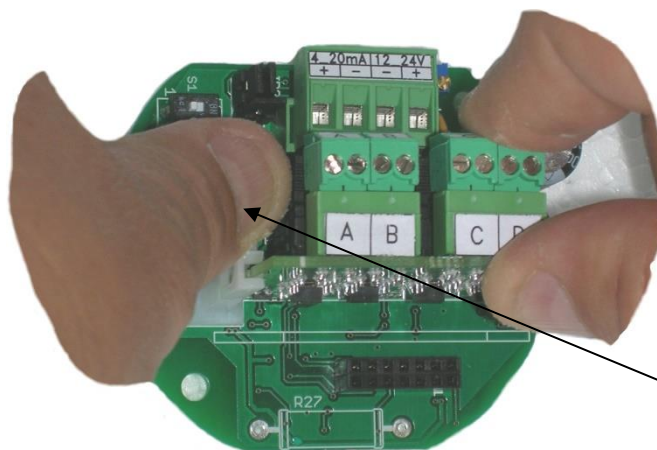



Elastic Flag

Phase 3:

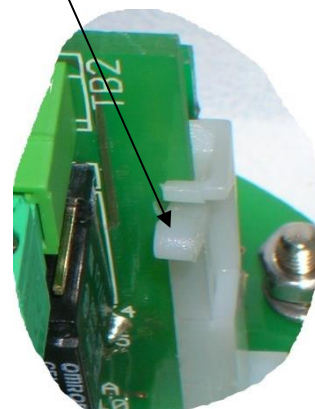
Check the position of the Relay Card.
Pay attention that all pins are in CN3 connector and that card is placed and fastened properly by the elastic flag.



EsiWelma srl		
TYPE URx20SP		
$V_{max}: 28 V_{dc}$ $P_{max}: 3,2 W$		
$12V 100mA (24V 50mA)$		
IP55		$-20 \leq T_a \leq +50 \text{ } ^\circ C$

Phase 4:

Tick the appropriate check box using a permanent marker.

Relay Card Electrical Installation

Type of contact selection:

After the mechanical installation of the Relay Card, the operator should provide to configure it selecting the type of contact (NO or NC) available on each terminal board, and direct or reverse operation mode of the relay.

For each relay a couple of terminals are available.
Use jumper **JP1...JP4** in order to select type of contact.

NC or NO contact of Pre-alarm relay
NC or NO contact of 1st threshold relay
NC or NO contact of 2nd threshold relay
NC or NO contact of sensor failure relay

DL1 (Yellow), Sensor FAILURE
DL2 (Red), 2nd alarm threshold
DL3 (Red), 1st alarm threshold
DL4 (Red), Pre-alarm

Type of contact selection (JP1÷JP4):

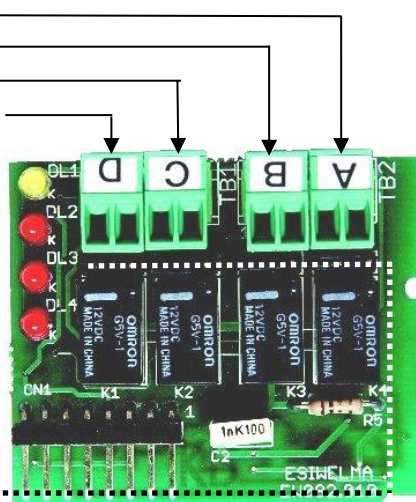
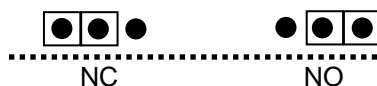

Direct or reverse operation mode:

In order to select the operation mode of the relays, operator has to use the 6th selector of the dip-switch in **S1** position, particularly:

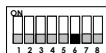

Direct operation mode:
(relay energized by event)



Reverse operation mode:
(relay energized without event)

Variable Resistance Output Electrical Installation

For the electrical connection of optional variable resistance output card, please refers to Third Part Central Unit operation.

For instance, the **UZS20.E** card have the following resistance levels:

- 22KOhm = normal operation
- 10KOhm = pre-alarm
- 2,2KOhm = 1st alarm threshold
- Open Circuit = Sensor FAILURE

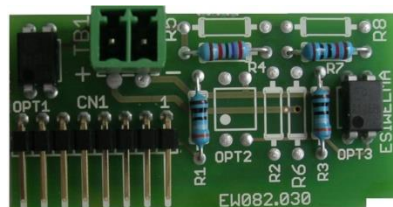

Preliminary check after the mechanical and electrical installation

The sensors are factory calibrated then they normally don't need any other calibration once installed. In any case, after the installation a functional check of the sensors is recommended.

Turning On the detector a 2 minutes preheating phase will occur. After this time the sensor will switch in normal operation mode, but the best performances will be reach after at least 2 hours.

When detector is full working a gas response should be verified using the TUL40.. Gas calibration kit. This Kit contains:

- 1 bottle of calibrated gas: 50% of L.E.L. for explosive gas or at 500ppm of CO; (see ordering codes on the specific instruction booklet)
- pressure valve/adapter and flow gauge
- head sensor adapter
- about 2 metres of pipe.

During the test the operator has to check the 4...20mA output current value, the state of the led on the sensor body and, if installed, the state of the led on relay card (cover must be removed).

Preliminary check after the mechanical and electrical installation (continue)

The status LED on the sensor body, and the 4...20mA output, have the following functional meaning:

Sensor Operating Mode	4...20mA Output	Status led on sensor body
PREHEATING	2mA	Blinks at 2 Hz
NORMAL OPERATION	4...20mA 0,10,20mA for threshold applications	1 Blink every about 10 sec.
PREALARM		2 Blinks every about 5 sec.
1 st ALARM THRESHOLD		3 Blinks every about 5 sec
2 nd ALARM THRESHOLD		4 Blinks every about 5 sec
SENSOR FAILURE	22mA	Fixed light

Applying the calibrated mixture of gas to 50% of the L.E.L. (or to 500ppm of CO) by the Gas calibration kit, check that the 4...20mA output signal is included from 10,5 to 13,5mA (from 18,5 to 21mA for CO).

In same way, the status led on the sensor body and the pre-alarm relay, 1st and 2nd alarm threshold, of the optional relay card, switch on as a result of the thresholds setting.

Maintenance

Every three/six months a sensor functional check should be provided.

Routine

Routine check provides the same test described in the chapter “preliminary check after mechanical and electrical installation”.

Corrective

For any anomaly found during recurrent maintenance of the sensors, operator has to send the sensor back to the supplier, who on his turn will return it to the manufacturer. To correct any calibration anomaly found during recurrent maintenance of sensors, operator can use **TUL40..** Gas calibration kit and **TUS40** service & maintenance terminal unit that has to be connected to the sensor by the communication interface (on the connector CN4) integrated in the same cable. For the calibration procedure, see the instructions given with service terminal.

Disassembly

Power off the detector, disconnect the wire on the terminals and dismount the housing from any blocking system.

Warranty

Warranty on EsiWelma products is valid 12 months from installation date and no longer that 24 months from manufacturing date placed on the product. Installation data, stamp and sign on the coupon filled in by the installer will be considered as a proof for warranty. In case of on warranty repairing, copy of the coupon has to be returned together with the product.

Accessories

UZR20.4	4 Relays Card
UZS20..	Opto-insulated variable resistance output Card
TUL40..	Gas calibration Kit
TUS40	Service & Maintenance Terminal Tools

Dimensions and weight: Dimension (HxWxD): 130x100x60mm.

Weight: 0,5Kg

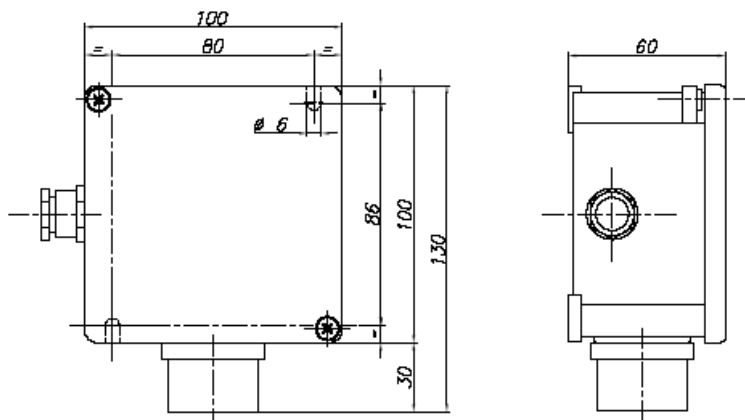

Installation data

<i>To be filled by Installer</i>		<i>Installer stamp and signature</i>
Installation site:		
Ordering code:		
Part Number:	Manufacturing date:	
Installation date:	Expiring date:	

Routine checks

<i>To be filled by Installer / Service Personnel</i>	<i>Signature</i>

Note

.....

.....

.....

.....

.....

.....

.....

.....

.....

.....

.....