

Sensigas®

Oxygen detectors

IP55 Protection Degree
MED/3.54 (IEC 60092-504) certified

URS41.L



Power supply 10÷28Vdc.
Electrochemical cell sensor, specifically designed for the detection of Oxygen (O₂).
Up to three intervention thresholds.
Automatic counting of sensor life time.
LED on the housing body to indicate the operating status and display option.

Use	<p>URS41.L are used to detect the Oxygen excess or deficiency in not classified areas (laboratories, hospitals, thermal power plants, etc..)</p> <p>An Oxygen excess forms if it leaks in hospitals, laboratories, welding centers and, more in general, where Oxygen is stored or employed.</p> <p>Oxygen deficiency is an indirect measurement of the presence of other explosive or asphyxiant gases that deplete the oxygen in the air.</p> <p>URS41.L sensors are designed for operation on Local BUS for interfacing with the Sensigas® UCE40MPA which, together with the MDD40 Display Module, perform monitoring tasks of the Gas Detection System</p> <p>The implementation of gas alarms takes place through the MAR40 Relay Modules.</p>
------------	---

Operation	In case of a gas leak, the sensor compares the measured concentration value with the set intervention thresholds, activating the relays associated with them. Any alarm information is sent to the Central Unit and the remote Relay and Display Modules according to the associations provided.
------------------	--

Ordering	Simply indicate product code: please, refer to “available models”.
-----------------	--

Available Models

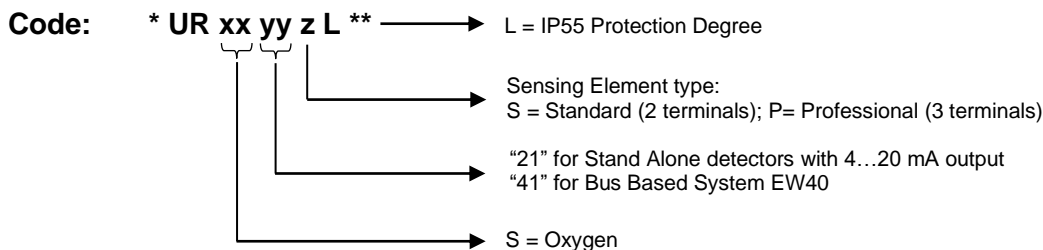

* Prefix to the name of the Detector: DR = Display with Relays; DN = Display without Relays;
** Suffix to the name of the Detector: EXR = Extended temperature range (**Not Available for Oxygen**)

Technical Characteristics

Note (1):

When the detector detects a very high gradient of increasing concentration, and the full scale value of 20% is exceeded, the sensitive element is powered off and the overrange is declared (fault condition for overrange) respectively. with:

- the 4 ÷ 20mA output which is set at 22mA;
- the output of the Fault Relay activated (relay energized or not depending on the selection made);
- the status LED visible from the outside on steady with an OFF blink of 0.5s every 5s
- the display (if present) explicitly declares the need for recalibration.

After the occurrence of a condition of this type, it is necessary to:

- make sure that the area is free of explosive mixtures;
- disconnect and power up the detector to allow the sensitive element to be powered and wait at least an hour to allow for thermal stabilization.

Only entering the calibration procedure can bring the detector out of this state.

As for all other operational contexts:

- if the recalibration procedure is successful it can bring the detector into normal operating status
- if the recalibration procedure is not successful, the detector is declared definitively faulty.

Sensor type	Electrochemical cell 2 or 3 Terminals	
Detected gas	O₂ Excess	O₂ Deficiency
Power supply	10÷28Vdc	
Maximum power consumption	1.2W	
Measuring range	0÷30% of Oxygen ⁽¹⁾	
Precision	± 5% of Full Scale, ± 10% of reading	
Repeatability	± 5% of Full Scale, ± 10% of reading	
Measurement Resolution (Sensitivity)	0,1% of Oxygen	
Microprocessor Resolution	4096 points (12 bit A/D Converter)	
Measuring digital processing	Kalman Filter	
Watch dog	External, acting on the whole Safety Chain	
Warm-up time	< 2 minutes after every power on	
Stabilization Time	2 hours from first power on	
Response Time (Max)	< 20s (T50), < 60s (T90)	
Average Sensor Life (in Air)	120 weeks	

Default alarm thresholds, editable from the Central Unit UCE40MPA or Service Terminal TUS40.. o Display Card)	Pre-alarm	19% O ₂
Operation and storage conditions:	1 st Threshold	17% O ₂
Environment Temperature (°C)	2 nd Threshold	15% O ₂
- Operating	-20 ÷ 50	
- Storage	-20 ÷ 70	
Relative Humidity (%UR) without cond.	15 ÷ 90	
- Operating	45 ÷ 75	
- Storage	80 ÷ 120	
Operating Pressure (kPa)	≤ 6	
Air Speed (m/s)	Red LED visible on the housing body	
Optical Signalling	See dedicated paragraph	
Dimensions and Weight		



0474 / xxxx (manufacturing year)
CERTIFICATE n. MED327120CS

MED Directive / Standards
EMC Directives / Standards
LVD Directives / Standards

MED 2014/90/EU / IEC 60092-504
EMC 2014/30/EU / EN50270 / EN 61326-1
Not applicable

Product Standard

EN60079-29-1

Options, Accessories and Spare Parts:

Display Options

Display Board without **DN-** Relay (Detector Name)

Display Board with Relay **DR-** (Detector Name)

Display Board are in fact the Operator Interface on board the Detector for control, monitoring, calibration and calibration operations. They manage:

- N. 4 Push Buttons used to give the operator commands;
- N. 4 SPDT Relay (only for DR- Board).

each Relay is associated with a Led for local Alarm or Sensor Fault signaling the state of the LEDs is directly associated to the status of the relative Relay: Relay X "On" => Led X "On"
N. 6 Heating resistors for Extended Range Detectors (**EXR** suffix)

TUL40.. Test Kit

The kit consists of at least one cylinder of calibrated gas, the dispensing valve, a precision flow meter and the flow chamber to put the detector under flow.

Kit components can be sold separately.

TUS40..Service Terminal Kit

Terminal necessary for the calibration of detectors not equipped with Display Board.

NRXX-Y-ZZZ replacement sensor body

Sensor body complete with relative signal conditioning board.

Sensor Lifetime

Sensor average lifetime (see technical characteristics) is referred to a typical usage in a pollution-free environment. Presence of a high concentration of pollutants can shorten the lifetime of the sensing element.

Do not use pure gas or the lighter directly on the Sensor which could be irreparably damaged.

CAUTION: consider that in particularly polluted environments or with vapours of flammable substances (in particular solvents), the useful life of the sensor can be considerably reduced. Some Substances cause a permanent reduction in sensitivity, preventing the Sensor from coming into contact with Silicone Vapours (present in Paints and Sealants), Lead Tetraethyl or Esters Phosphates. Other substances cause a temporary loss of Sensitivity, these "Inhibitors" are Halogens, Hydrogen Sulphate, Chlorine, Chlorinated Hydrocarbons. In the latter case, after a short time in Clean Air, the Sensor resumes its normal operation.

Once the detection system starts up, it has to be supplied with energy during all the lifetime of its sensors.

Seasonal use is not recommended.

Mechanical Installation

For Sensors installation, follow the rules as in the diagram:

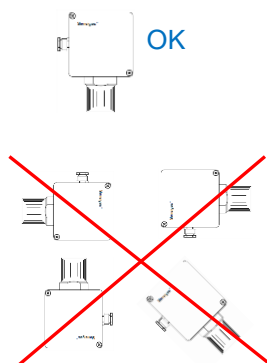

Oxygen Excess

Since oxygen has about the same weight as air, unless forced or natural air circulation, it will tend to spread where the loss occurred or a little lower. For this reason, excess oxygen detectors must be installed near the possible leaks, in order to detect the excess in the shortest possible time.

Oxygen Deficiency

Detection of oxygen deficiency aims to indirectly reveal the presence of other gases that replace the air and which can therefore, for example, cause asphyxiation problems. In this case, the positioning of the detectors must be carried out at the breathing height of the occupants of the premises

Positioning of the sensors must take into account not only the aforementioned general rules, but also the following installation rules; in particular the sensors must be installed:

- Near possible gas leak points;
- At least 1.5m from heat sources and ventilation openings;
- Never in poorly ventilated areas where gas pockets may occur and, more generally, away from obstacles to the natural movement of the gas;
- Far from appliances that throughout their normal working can have functional gas leakage (unless this is the purpose of the detection);
- In environments where atmospheric conditions are not included in the technical characteristics.
- The assembly and disassembly of the sensors must be carried out when the appliance is not live.

The number of sensors to be installed in an environment is proportional to its surface, its height and conformation, as well as the relative density of the gas.

The installation must also take into account:

- The geometry of the structures (beams, false ceilings, wells, etc.)
- Mechanical and liquid protection
- Poisoning protection
- Accessibility for appliance maintenance.

The installation of the detectors must take place as late as possible to avoid damage, but in time to adequately protect the environment for which they are intended.

Environmental Compatibility and Disposal



This product has been developed and built using materials and processes that take into account the environmental issue. Refer to the following notes for disposal of the product at the end of its life, or in case of its replacement:

- for the purpose of disposal, this product is classified as an electrical and electronic device: do not dispose of it as household waste, in particular as regards the printed circuit
- comply with all local laws in force
- facilitate the reuse of basic materials as much as possible in order to minimize the environmental impact
- use local depots and waste recycling companies, or refer to the supplier or manufacturer, to return used products or to obtain further information on environmental compatibility and waste disposal

The product packaging is reusable. Keep it for possible future use or in case of returning the product to the supplier.

Electrical Installation and Configuration

CAUTION: Make the area safe and ensure that the device power supply is off before cabling and configuration operations.

Install the sensor in compliance with local Standards.

To enter cables, uses the cable gland provided on the housing.

The cable sheath cannot be larger than 8mm.

Ground the sensor using the internal grounding system.

Refer to the Control Unit manual for all cabling information (cable type and specifications, bus topology, length of connections etc.) and configuration.

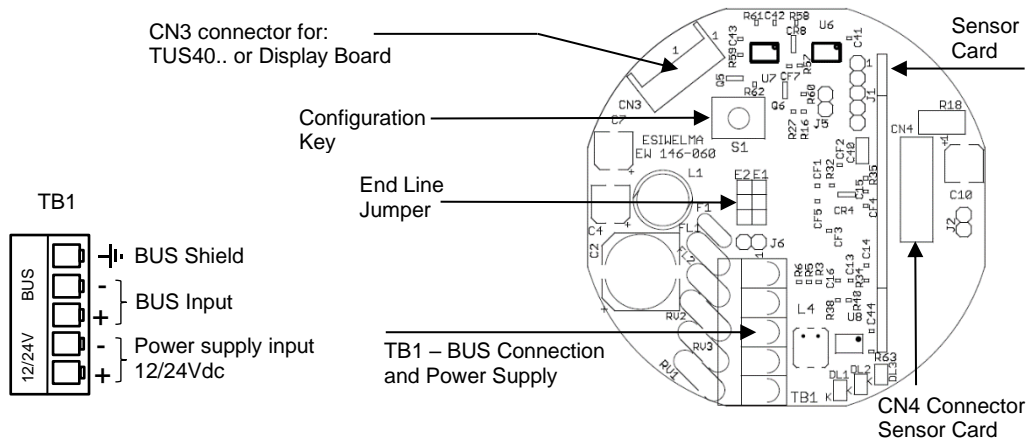

Preliminary checks after mechanical and electrical installation

Before being used, the sensor must be recognized by the UCE40MPA Central Unit with an affiliation operation (refer to the Manual of the aforementioned Central Unit for proper execution of the configuration and commissioning operations).

The sensor is calibrated in the factory and therefore there are no calibration operations once installed for the first time; however, after installation it is necessary to perform a functional check of the sensors. The status LED has the following meaning:

Troubleshooting

For troubleshooting, having only one LED that identifies the functional states described in the table opposite, in the event of a fault or functional anomaly, in addition to the usual checks on the correct power supply and wiring, it is necessary to have the **TUS40** .. service terminal (or use the Display Board, if present) and refer to the relevant product documentation. See also Note 1 in the technical characteristics for the FAULT for OVER-RANGE

Sensor Status	Status Led on Sensor Body
PRE-HEATING	Flashing with Frequency 2 Hz
WORKING	1 Pulse "ON" every 10s
PRE-ALARM	2 Pulses "ON" every 5s
1 st THRESHOLD ALARM	3 Pulses "ON" every 5s
2 nd THRESHOLD ALARM	4 Pulses "ON" every 5s
FAILED SENSOR	Steady "ON"
FAIL for OVER-RANGE	Steady "ON", 1 Pulse "OFF" every 5s

Periodic Maintenance

Every three/six months a functional check must be carried out:

- In free air, the measurement indicated on the Central Unit must be $20.9 \pm 1\%$ of O_2 .
- The appropriate gas mixture is applied using the **TUL40** .. test kit, the measurement indicated on the Central Unit is close to the concentration of the cylinder used $\pm 1.5\%$ of O_2 .

Any functional anomalies found during the periodic checks of the sensors can be identified and corrected with the TUS40 .. service terminal or with the display board, if present; in the absence of these devices, send the detector to your Supplier / Installer, who will send it to EsiWelma.

Dimensions and Weight

Dimensions (HxWxD):

130x100x60mm

Weight: 0,5Kg

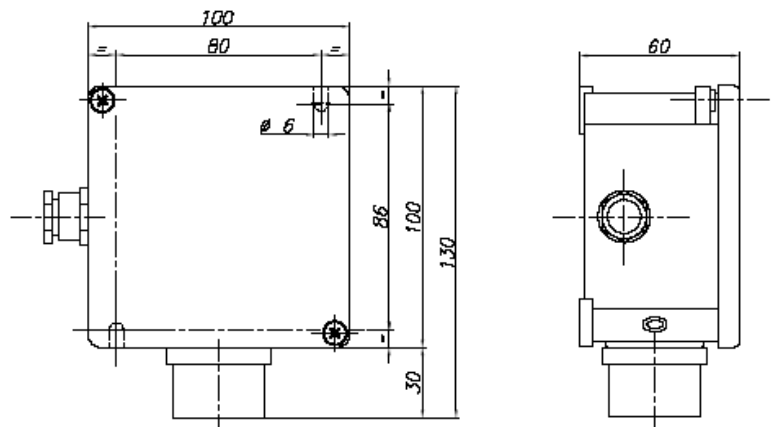

Due to our policy of continuous product improvement, specifications are subject to change without notice.