

Sensigas®

Gas Detectors

ATEX II 2G Ex d IIC T6⁽¹⁾ Gb certified
MED/3.54 (IEC 60092-504) certified

UR.21.E



Power supply 10÷28Vdc. Sensitive elements:

- Catalytic (S and P), Infrared (I) or Semiconductor (T) for flammable gases,
- Electrochemical cell (S or P), Infrared (I) or Semiconductor (T) for toxic and refrigerant gases.

Up to three intervention thresholds. Automatic counting of the lifetime of the sensors.
LED on the sensor body to indicate the operating status and display option.

Use

UR.21.E detectors are used to detect, by diffusion, the presence of:
Methane Gas, LPG, Carbon Monoxide (CO), Petrol Vapours, Acetylene, Hydrogen, Ammonia (LIE and Toxicity), Propane, Octane, Ethyl Alcohol (Ethanol), Oxygen, Carbon Dioxide, Xylene, Acetone, Hexane, Cycle- Hexane, Toluene, Pentane, Butane, Heptane, Ethane, Methanol, Benzene, Ethyl Acetate, Cyanuric Acid, Sulphuric Acid (Hydrogen Sulphate), Hydrochloric Acid, Chlorine, Nitrogen Monoxide, Nitrogen Dioxide, Nitrous Oxide, Ethylene Oxide, Biogas and, more generally, Hydrocarbons, as well as flammable and non-flammable Refrigerants, in areas classified as Zone 1 in industrial environments, thermal power stations or similar places.

The UR.21.E detectors are designed for Stand-Alone operation with a 4÷20mA output and for interfacing with the Sensigas® UCE1 and UCE4 Central Units and, more in general, with any Central Unit, PLC, Module of I / O that has 4÷20mA inputs.

Operation

In case of a gas leak the sensor compares the measured concentration value with the intervention thresholds set by activating the relays or the resistive outputs (if provided) associated with them. The information of the measured concentration value is always present on the 4 ÷ 20mA output.

Ordering Simply indicate product code: please, refer to “available models”.

Available models:



Code: * UR xx yy z E **

- E = Explosion Proof Execution
- Sensing Element type:
S = Standard; P = Professional; I = Infrared; T = Standard with Threshold operation.
- “21” for Stand Alone detectors with 4...20 mA output
“41” for Bus Based System EW40
- G = Methane; P = LPG; O = Carbon Monoxide; B = Gasoline Vapours; L = Acetylene;
I = Hydrogen; M = Ammonia (LIE); C = Propane; T = Octane; E = Ethyl Alcohol;
S = Oxygen; D = Carbon Dioxide; X = Xylene; A = Acetone; H = Hexane;
Q = Cycle-Hexane; T = Toluene; N = Pentane; U = Butane; F = Heptane; K = Ethane;
J = Ammonia (Toxicity); V = Methanol; Z = Benzene; Y = Ethyl Acetate;
W = Hydrocyanic Acid; HS = Sulphuric Acid; HC = Hydrochloric Acid; CL = Chlorine;
N1 = Nitrogen Monoxide; N2 = Nitrogen Dioxide; N3 = Nitrous Oxide,
EO = Ethylene Oxide; GD = Biogas; HY = Hydrocarbons; R = Refrigerants.

* Prefix to the name of the Detector: DR = Display with Relays; DN = Display without Relays;

** Suffix to the name of the Detector: EXR = Extended temperature range -40... + 70°C.

Technical Characteristics

| | | |
|--|--|---------------------------------------|
| Sensor type | Catalytic, Infrared, or Semiconductor | Electrochemical Cell or Semiconductor |
| Detectable Gas (see available models) | Explosive Gases ⁽²⁾ | Toxic Gases (e.g.: CO) |
| Power Supply | 10÷28Vdc | 10÷28Vdc |
| Maximum Power Consumption (@ 28Vdc with 4÷20mA with s.c. output) | 2,4W (4W with UZR20.4) | 1,2W (2,8W with UZR20.4) |
| Measuring range | 0÷100% LEL ⁽³⁾ | 0÷500 ppm |
| Precision (Catalytic, E.C., NDIR) | ± 5% of Full Scale, | ± 10% readout |
| Precision (Semiconductor) | ± 10% of Full Scale | (on calibration point) |
| Repeatability | ± 5% of Full Scale, | ± 10% readout |
| Measurement Resolution (Sensitivity) | 1% LEL | 5 ppm |
| Microprocessor Resolution | 4096 points (12 bit A/D Converter) | |
| Digital Filter system | Kalman Filter and zero drift compensation | |
| Watch dog | External, acting on the whole Safety Chain | |
| Warm-up Time | < 2 minutes after every power on | |
| Stabilization Time | 2 hours from first power on | |
| Response Time (Max) | < 20s (T50), < 60s (T90) | |
| Average Sensor Life (in Air) | 255 weeks | 255 weeks |
| Output 4÷20mA signal type: | | |
| Proportional Output (default) | - 4mA = 0% LEL; | 0 ppm |
| Step Output (1 o 2 thresholds application) | - 20mA = 100% LEL; | 500 ppm |
| | - 0mA = no Alarm | |
| | - 10mA = 1 st Threshold Alarm | |
| | - 20mA = 2 nd Threshold Alarm | |
| Settable reference of 4÷20mA signal | With jumpers (reference to negative or positive of power supply) | |
| Load Resistance of 4...20mA output (with generator limited to 24mA) | Minimum 0Ω @ 28Vdc | Maximum 300Ω @ 10Vdc |
| Operation and storage conditions: | | |
| Environment Temperature (°C) | | |
| - Operating | -20 ÷ 50 or -40 ÷ 70 (Extended Range) | |
| - Storage | -20 ÷ 70 | |
| Relative Umidity (%UR) without condens. | | |
| - Operating | 15 ÷ 90 | |
| - Storage | 45 ÷ 75 | |
| Operating Pressure (KPa) | 80 ÷ 120 | |
| Air Speed (m/s) | ≤ 6 | |
| Optical Signalling | Red LED visible on the sensor body | |
| Dimensions and Weight | See dedicated paragraph | |
| MED Marking |  0474 / xxxx (manufacturing year) CERTIFICATE n. MED327120CS | |
| ATEX Marking |  1370  II 2G Ex d IIC T6 ⁽¹⁾ Gb BVI 07 ATEX 0032 + EXT 03/19 -20°C ≤ T _A ≤ +50°C -40°C ≤ T _A ≤ +70°C (Extended Range) | |

Note ⁽¹⁾: Some Detectors of the DR-UR.21.E-EXR type, ie equipped with Display Board with Relay (prefix **DR-**), with extended temperature range (suffix **-EXR**) and which use Catalytic or Infrared sensitive elements, ie with particular absorption characteristics, have temperature class T5 instead of T6.

Note ⁽²⁾: Detectors using Catalytic Sensing Elements are sensitive to all Flammable Gases, with different sensitivities and responses related to Methane Gas (see Tables contained in the Display Board and Service Terminal Manuals), through which these relative responses can be inserted in the Detector.

Note ⁽³⁾: When Detector detects a very high gradient of increasing concentration, and the full-scale value of 20% is exceeded, power is removed from the sensing element and the out-of-range (fault condition for overrange) is declared respectively with:

- the 4÷20mA output which is set at 22mA;
- fault relay output activated (relay energized or not depending on the selection made);
- the status LED visible from outside fixed on with an OFF flash of 0.5s every 5s
- display (if present), explicitly declares the need for a recalibration.

After such a condition occurs:

- make sure the area is free of explosive mixtures;
- turn off and turn on the detector to allow the sensing element to be powered and wait at least an hour to allow thermal stabilization.

Only entering the calibration procedure can bring the detector to exit the overrange fault state.

As with all other operational contexts:

- if the recalibration procedure is successful, it can bring the detector into normal operating status;
- if the recalibration procedure is not successful, the detector is simply declared faulty.

**Technical characteristics
(continued)**

4 Relay SPDT Card UZR20.4⁽⁴⁾

It is used to activate signals and/or external systems (light signals, sirens, ventilation systems, etc.).

NO or NC contacts available, selectable by jumpers.

N. 4 LEDs are present and associated with the status of each Relay and separate quick-connecting term. blocks

The state of the LEDs is directly associated with the status of the relative Relay: Relay X "On" => Led X "On".

Relay contact range:

Relay control logic:

Note ⁽⁴⁾: not insertable if the Display Board **DR..** or **DN...** is present

(default values for explosion gas and CO)

Relay A: Pre-alarm (10% LEL, 50 ppm)

Relay B: 1st Thresh. Alarm (20% LEL, 100 ppm)

Relay C: 2nd Thresh. Alarm (40% LEL, 200 ppm)

Relay D: Detector Fail

Alarm intervention thresholds can be reset by dip-switch (15 combinations) or by service and maintenance terminal or display.

50mA @ 24Vac/dc, 100mA @ 12Vac/dc

- Direct: Relay ON in the presence of an event;
- Inverse: Relay ON in the absence of an event.

Display Board without Relay **DN-DetName**.

Display Board with Relay **DR-DetName**.

Display Boards are in fact the Operator Interface on board the Detector for control, monitoring, calibration and calibration operations. They manage:

N. 4 Sensors for Magnetic Actuator used to give the operator commands;

N. 4 SPDT Relay (only for DR .. Board)

Each Relay is associated with a Led for the local Alarm or Sensor Fault signaling The state of the Leds is associated directly to the status of the relative Relay: Relay X "On" => Led X "On"

N. 6 heating resistors for Extended Range Detectors
(suffix **-EXR** to the name of the detector)

PhotoMOS Card **UZS20..**

It is used to indicate the status of the detector through a resistive value presented at the terminals.

| UZS20.E | <u>Normal</u> | <u>Pre-Al</u> | <u>1st Th</u> | <u>2nd Th</u> | <u>Fail</u> |
|----------------|---------------|---------------|--------------------------|--------------------------|-------------|
| | 22kΩ | 10kΩ | 2,2 kΩ | n.p. | Open |

It is typically used in conjunction with modules that put on the LOOP peripheral fire alarms that have a behavior similar to that of smoke detectors.

| UZS20.A | <u>Normal</u> | <u>Pre-Al</u> | <u>1st Th</u> | <u>2nd Th</u> | <u>Fail</u> |
|----------------|---------------|---------------|--------------------------|--------------------------|-------------|
| | 27kΩ | n.p. | 10kΩ | n.p. | Open |

| UZS20.S | <u>Normal</u> | <u>Pre-Al</u> | <u>1st Th</u> | <u>2nd Th</u> | <u>Fail</u> |
|----------------|---------------|---------------|--------------------------|--------------------------|-------------|
| | 2,2kΩ | n.p. | Close | n.p. | Open |

Magnetic Actuator Card **UZMAG**

The card for the UCM magnetic actuator, allows the calibration of the detector without the opening of the housing which would require the declassification of the area at risk of explosion in which the detector finds use.

It connects to the detector through the same connector as the display board and is therefore an alternative to it.

Verification and Calibration Kit **TUS40..**

Service and Maintenance Terminal with Interface Board **UIC20**.

See Chapter for Commissioning and Start-up.

Replacement Sensor Body **NRXX-Y-ZZZ**

Sensor body complete with relevant signal conditioning card.

See dedicate price list.

Sensor Lifetime

Sensor average lifetime (see technical characteristics) is referred to a typical usage in a pollution-free environment. Presence of a high concentration of pollutants can shorten the lifetime of the sensing element.

The Catalytic Sensor only works in the presence of Oxygen. Do not use pure gas or the lighter directly on the Sensor which could be irreparably damaged.

CAUTION: consider that in particularly polluted environments or with vapors of flammable substances (in particular solvents), the useful life of the sensor can be considerably reduced. Some Substances cause a permanent reduction in sensitivity, preventing the Sensor from coming into contact with Silicone Vapours (present in Paints and Sealants), Lead Tetraethyl or Esters Phosphates. Other substances cause a temporary loss of Sensitivity, these "Inhibitors" are Halogens, Hydrogen Sulfate, Chlorine, Chlorinated Hydrocarbons. In the latter case, after a short time in Clean Air, the Sensor resumes its normal operation.

Once the detection system starts up, it has to be supplied with energy during all the lifetime of its sensors.

Seasonal use is not recommended.

Mechanical Installation

For Sensors installation, follow the rules as in the diagram:

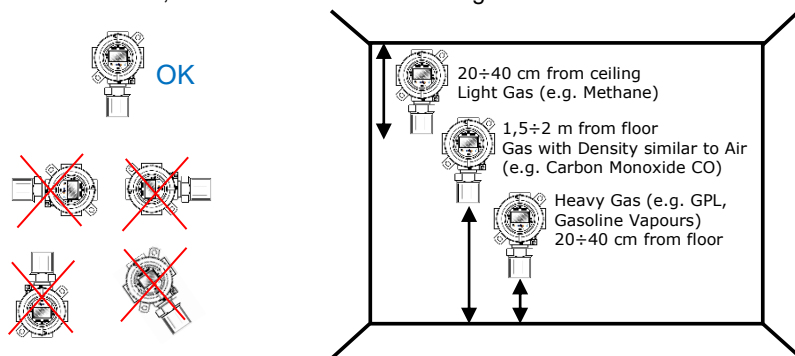

The positioning of the sensors must take into account not only the aforementioned general rules, but also the following installation rules; in particular the sensors must be installed:

- Near possible gas leak points;
- At least 1.5m from heat sources and ventilation openings;
- Never in poorly ventilated areas where gas pockets may occur and, more generally, away from obstacles to the natural movement of the gas;
- Far from appliances that throughout their normal working can have functional gas leakage (unless this is the purpose of the detection);
- In environments where atmospheric conditions are not included in the technical characteristics.
- The assembly and disassembly of the sensors must be carried out when the appliance is not live.

The number of sensors to be installed in an environment is proportional to its surface, its height and conformation, as well as the relative density of the gas.

The installation must also take into account:

- The geometry of the structures (beams, false ceilings, wells, etc.)
- Mechanical and liquid protection
- Poisoning protection
- Accessibility for appliance maintenance.

The installation of the detectors must take place as late as possible to avoid damage, but in time to adequately protect the environment for which they are intended.

Special Advise

CAUTION: Safety is guaranteed only if cover is properly tightened and locked.

- Tighten the cover in a clockwise direction, then verify that between case and cover there are no more than 0,5mm: it assures a perfect closing. Remember to tighten the grain placed on the cover.
- Respect the warning "DO NOT OPEN WHEN ENERGIZED" written on the cover, or declass the area before opening the cover.

Electrical Installation

CAUTION: Make sure that the area is safe and that the device has been disconnected from the power supply before starting any wiring and configuration operation.

Sensor installation must be carried out in accordance with EN60079-14. For cable entry, use 1 "NPT cable gland union ATEX Certificate and compliant with EN60079-0 and EN60079-1 (Ex d protection mode). The sensor must be earthed using the appropriate system provided.

Terminal Block and electric connections

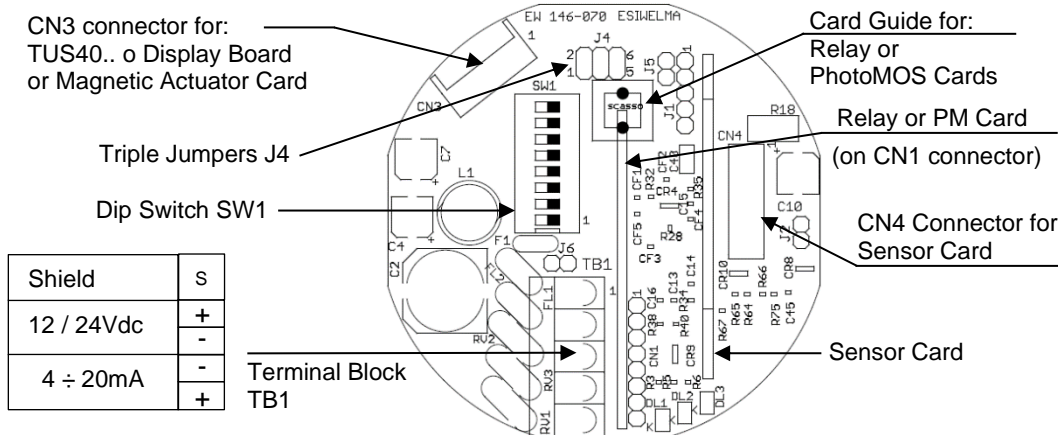

Cabling:

Depending on the connection distance, use a cable with at least 3 conductors with a minimum section of 0.75mm² up to 100m, 1mm² up to 200m, 1.5mm² up to 500m. In the presence of electromagnetic disturbances use shielded cable. If the relay board is present, use a multipolar cable suitable for the number of connections. The cable sheath must not exceed the diameter required by the cable gland.

Configuration:

Sensor is supplied with a basic programming which is the one indicated as default in the chapter of the technical features. To change these settings, disconnect the device, make all the necessary settings using the triple jumpers **J4** or the Dip Switch **SW1** shown in the figure and supply the device again; in particular:

4...20mA Output Reference Selection:

Sensor is basic set to have the negative of the supply signal as the 4÷20mA signal reference; to change this setting it is necessary to move the triple jumpers **J4** as shown in the figure:

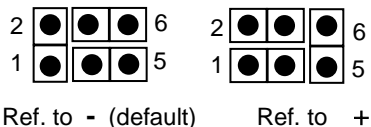

4...20mA Output Signal Type Configuration:

To set the 4...20mA output signal type, operator has to use the 5th selector of the dip-switch in **SW1** position, particularly:

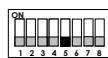

Proportional Output (4÷20mA)



Step Output (0-10-20mA)

Alarm Thresholds Settings:

To set the intervention thresholds of the optional relay board or of the 4÷20mA output threshold operation, it is necessary to act on the first four dip-switch selectors of the **SW1** position; in particular thresholds expressed as a percentage of the Full Scale are the following:

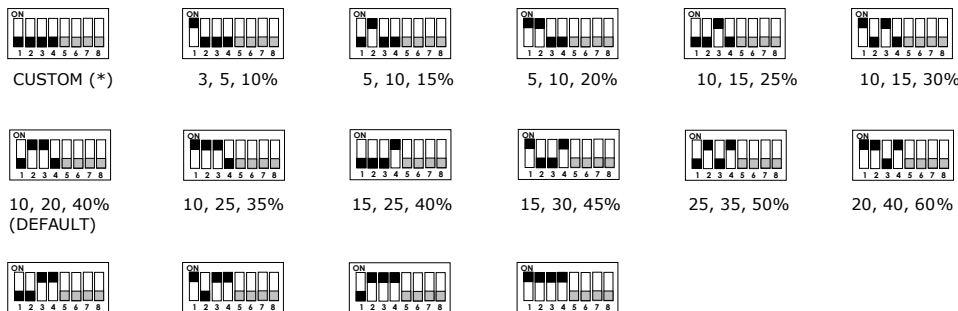

(*) When the first four dip-switch selectors are in the OFF position, the trip thresholds can be only set by TUS40.. service and maintenance terminal or via Display (DR ... or DN Board ...).

In the event that this selection is made without the presence of the service terminal, the device will take the default thresholds as intervention thresholds. For the use of the terminal see the relative operating manual.

If the Display Board DR- or DN- is present, TUS40.. terminal is not usable.

-----Future Implementation-----

Mechanical installation of the optional Relay Card or optional PhotoMos Cards with resistive output variation

On the main electronic card it is possible to insert, in a special connector named **CN1**, a module having on board N. 4 relays with changeover contact that will be activated in correspondence of the pre-alarm events, 1st alarm threshold, 2nd alarm threshold and faulty sensor, and the relative LEDs signaling. Follow the steps below to insert the card:

Phase 1:

Insert on the main electronic card the card guide supplied with the card, taking care to turn the elastic flag towards the main terminal board. Locate the connector **CN1**.

Card Guide (with Elastic Flag)

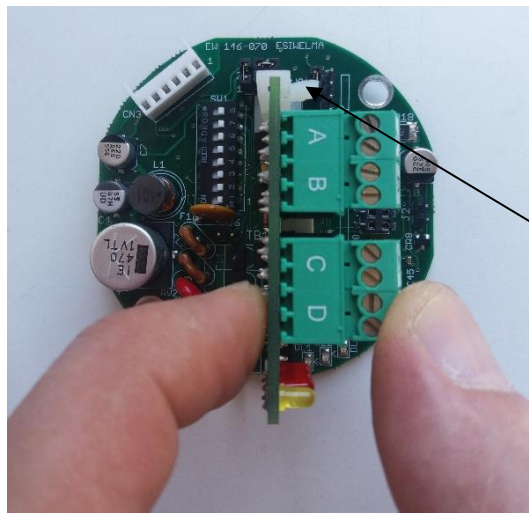
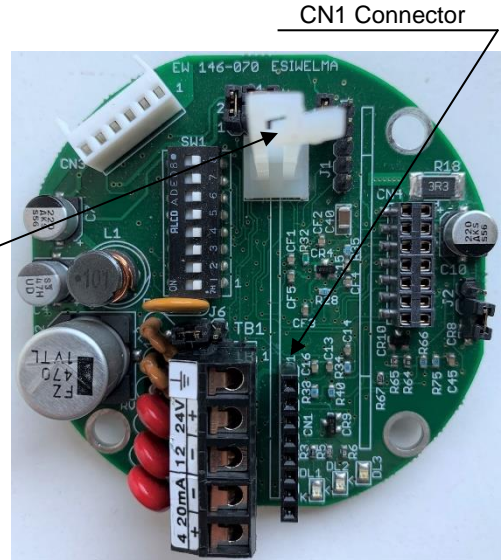

Phase 2:

Fully insert the card, taking care to pull the elastic flag of card guide towards the terminal board of the optional card.

Elastic Flag

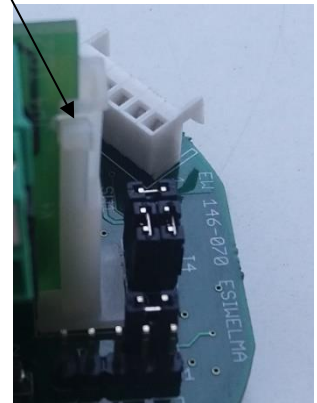

Phase 3:

Check the positioning of the card checking that all pins are internal to the CN1 connector and that, by practicing a slight pull upwards, the card remains in position due to correctly hooked and held by the elastic flag of the card guide.

| | | | |
|-------------------------------------|----------------------|----------------------|------|
| EsiWelma® srl | | | NNNN |
| TYPE URX21PE | | ITALY | PPPP |
| Vmax: 28 Vdc Pmax: 3,2 W | | BVI AA ATEX CCCC | |
| 12V 100mA (24V 50mA) | | -20 °C ≤ Ta ≤ +50 °C | |
| | II 2G Ex d IIC T6 Gb | | |

Phase 4:

Mark the box showing the presence of the relay card inside the device with a permanent marker (example).

Electrical installation of the optional relay card

After the relay card is mechanically installed it is necessary to provide for its electrical configuration by selecting the relay control logic and the type of contact that is required on the terminal board (NC or NO).

Type of contact selection:

For each relay there is a pair of removable terminals to which the type of contact (NC or NO) can be associated, selectable by jumpers **JP1...JP4** of the relay card.

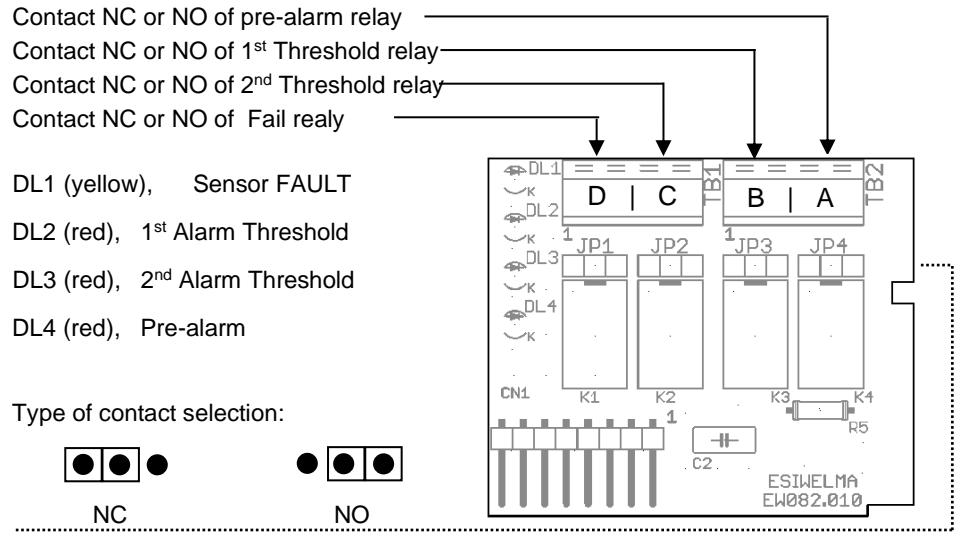

Setting of relay control logic:

To perform the setting of the control logic of the direct relays (relay energized in the presence of an event) or reverse (relay energized in the absence of an event), it is necessary to act on the 6th dip-switch of the **SW1** selector; in particular:



Preliminary checks after mechanical and electrical installation

Sensor is calibrated at the factory and therefore no calibration operations are planned once installed; however, after installation it is necessary to perform a functional check of the sensors. When the device is powered, it will set itself in the sensor preheating phase, which lasts about 2 minutes.

After this time the sensor will go into the normal operating state, however the best performance will be obtained after about 2 hours.

With the operating sensor it is necessary to verify its response using the specific TUL40 test kit consisting of:

- 1 calibrated gas bottle to 50% of the LEL of the Methane or to 500ppm of CO (see ordering codes of the test kit on the specific technical sheet);
- special pressure reducer and flow regulator TUL40.FLUX or equivalent, so as to guarantee a flow of about 0,5 liters / minute;
- universal adapter to adapt to the sensor body (URCAP.ESI);
- connection pipe between the cylinder and adapter, approximately 2m long.

During the test it is necessary to observe the value of the output current, the status of the LED visible outside the sensor body and, if present, the status of the LEDs on the relay board, before closing the case.

The LED on the sensor body and the 4÷20mA output have the following functional meaning:

| Sensor State | 4÷20mA Output | State Led on Sensor Body |
|---------------------------------|--------------------------------------|------------------------------|
| PREHEATING | 2mA | Flashing with 2 Hz frequency |
| WORKING | 4÷20mA | 1 pulse "ON" every about 10s |
| PRE-ALARM | 0,10,20mA for threshold applications | 2 pulses "ON" every about 5s |
| 1 st ALARM THRESHOLD | | 3 pulses "ON" every about 5s |
| 2 nd ALARM THRESHOLD | | 4 pulses "ON" every about 5s |
| FAILED SENSOR | 22mA | ON steady |
| OVER-RANGE FAILURE | 22mA | 1 pulse "OFF" every about 5s |

After applying the gas mixture at 50% of the LEL of the Methane gas (or at 500ppm for the CO) using the test kit (test gas application time > 2 minutes), make sure that the 4÷20mA output is between the 11 and 13 mA for Methane (or between 19 and 21mA for CO), the status LED flashes with 4 pulses every 5 seconds and the prealarm, 1st and 2nd alarm thresholds relays of the relay board are energized (or de-energized if SW1.6 is set to ON).

Troubleshooting

For troubleshooting, having only one LED that identifies the functional states described in the table above, when operating anomalies occur, in addition to the usual power and wiring checks, it is necessary to use the TUS40 terminal or use the Display Board (if present) and refer to the relevant product documentation (see also Notes 2 and 3 in technical features for Over-Range Failure).



| | |
|--------------------|--|
| Maintenance | Every three to six months a functional check of the sensors must be carried out, in accordance with the instructions contained in Standard EN60079-29-2. |
| Routine | The routine check involves the performance of the same tests as described in the chapter concerning preliminary checks after mechanical and electrical installation. |
| Corrective | Any failure found during the periodic checks of the sensors must be followed by sending the sensor to your Supplier / Installer, who will send it to EsiWelma. Possible sensors non-calibration found during the periodic checks can be identified and corrected with the help of the TUL40.. test kit .. and the TUS40.. service terminal, (or of the display board) which must be connected to the sensor (on the CN3 connector) through the appropriate communication interface integrated in the cable. For the sensor recalibration procedure, refer to the documentation supplied with the service terminal, the display board or the card for the magnetic actuator. |
| Disassembly | Power off the detector, disconnect the wire on the terminals and dismount the housing from any blocking system. |

| | |
|-----------------|--|
| Warranty | Warranty of the products is indicated in the General Sale Conditions to which reference is made. |
|-----------------|--|

| | | |
|------------------------------------|--|---|
| Accessories and Spare Parts | <ul style="list-style-type: none"> - Relay Card with n. 4 SPDT relay UZR20.4 - Display Board with Relay DR (Det.Name) - Display Board without Relay DN (Det.Name) - PhotoMOS Card UZS20.. - Magnetic Actuator Card UZMAG | <ul style="list-style-type: none"> - Magnetic Actuator UCM - Test Kit TUL40.. - Service Terminal Kit TUS40.. - Sensor Body NRXX-Y-ZZZ |
|------------------------------------|--|---|

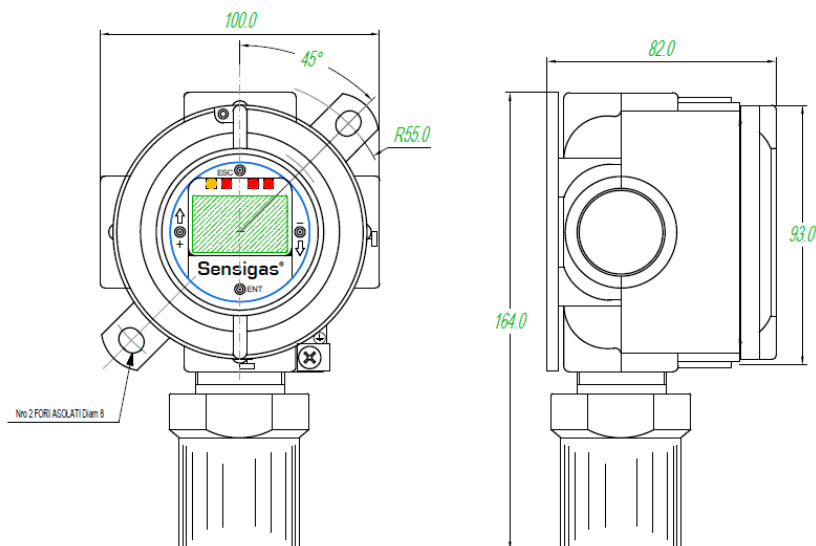
| | | |
|------------------------------|-----------------------------------|---------------|
| Dimensions and Weight | Dimensions (HxWxD): 164x100x82mm. | Weight: 0,8Kg |
|------------------------------|-----------------------------------|---------------|



| | | |
|-------------------------------|--|--|
| Legend of ATEX Marking |  1370  | Marking in compliance with all applicable Directives Identification number of the Notified Body for manufacturing survey Marking for all equipment in conformity to ATEX 2014/34/EU Directive II Equipment Group for surface industry 2 Equipment Category 2 for use in Zone 1 G Equipment intended for use in explosive gas atmosphere, caused by mixture of air and gas, vapours, flammable mists. Ex d IIC T6 ⁽¹⁾ Gb Type of protection according to EN60079-0, EN60079-1 and EN60079-29-1 BVI 07 ATEX 0032 EC Type Examination Certificate and possible extensions -20°C ≤ TA ≤ +50°C Environmental temperature range of the appliance (Standard) -40°C ≤ TA ≤ +70°C Environmental temperature range of the appliance (Extended Range) |
|-------------------------------|--|--|

Note ⁽¹⁾: Some Detectors of the DR-UR.21.E-EXR type, i.e. equipped with Display Board with Relay (prefix **DR-**), with extended temperature range (suffix **-EXR**) and which use Catalytic or Infrared sensing elements, i.e. with particular absorption characteristics, have temperature class T5 instead of T6.

Due to our policy of continuous product improvement, specifications are subject to change without notice.